

Optional Glass wind Screen

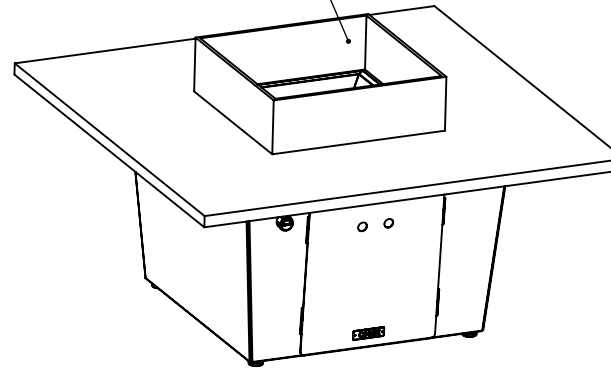

The Newport fire pit table is perfect for casual dining at 22 inches high, great for restaurants and social settings plus it can hide a standard propane tank in the base.

- Top Material
Granite Tier 1,2,3, Stainless steel or Custom selection

- Base Options
Copper plating with option of forced patina
Brushed or polished 304 stainless steel
Powder coating in several standard colors or custom colors are available

- Fire pit media
Broken Glass, Lava rock
Custom options include Ceramic stones, logs , etc.

- Fuel 60,000 BTU
Propane or Natural gas

- Optional forced air heat requires a 120 v 15 amp switched power

- Optional electronic Ignition requires 120v switched power

- Optional LED Lighting requires 120v switched power or Battery pack

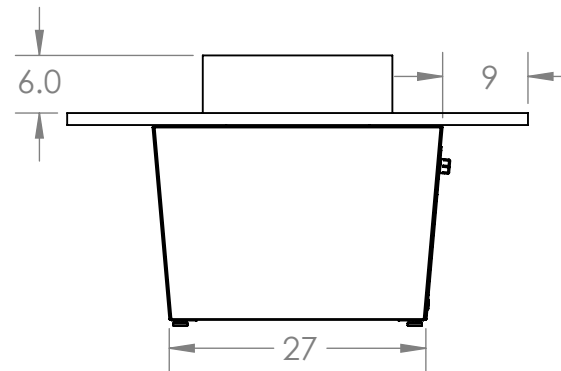
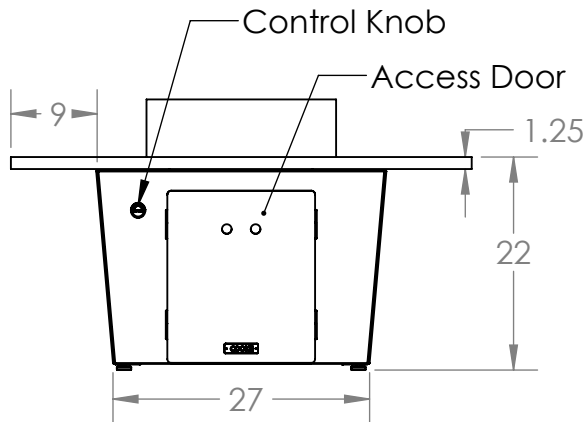

UNLESS OTHERWISE SPECIFIED:		PROPRIETARY AND CONFIDENTIAL																	
DIMENSIONS ARE IN INCHES TOLERANCES: FRACTIONAL $\pm 1/32$ ANGULAR: MACH $\pm .5^\circ$ BEND $\pm 1^\circ$ TWO PLACE DECIMAL $\pm .05$ THREE PLACE DECIMAL $\pm .010$		THE INFORMATION CONTAINED IN THIS DRAWING IS THE SOLE PROPERTY OF DCI LLC. ANY REPRODUCTION IN PART OR AS A WHOLE WITHOUT THE WRITTEN PERMISSION OF DCI LLC IS PROHIBITED.																	
INTERPRET GEOMETRIC TOLERANCING PER: ANSI		COMMENTS:																	
MATERIAL 304 SS/Stone		<table border="1"> <tr> <td colspan="2">COOKE</td> <td rowspan="2">CONTEMPORARY FURNITURE</td> </tr> <tr> <td colspan="2">info@cookefurniture.com 888-303-2453</td> </tr> <tr> <td colspan="3">TITLE: Newport Fire Pit Table 48x48x22</td> </tr> <tr> <td>SIZE A</td> <td>DWG. NO. NPLL-ASM-48x48x22</td> <td colspan="2">REV A</td> </tr> <tr> <td colspan="2">SCALE: 1:16</td> <td>WEIGHT:</td> <td>SHEET 1 OF 1</td> </tr> </table>		COOKE		CONTEMPORARY FURNITURE	info@cookefurniture.com 888-303-2453		TITLE: Newport Fire Pit Table 48x48x22			SIZE A	DWG. NO. NPLL-ASM-48x48x22	REV A		SCALE: 1:16		WEIGHT:	SHEET 1 OF 1
COOKE				CONTEMPORARY FURNITURE															
info@cookefurniture.com 888-303-2453																			
TITLE: Newport Fire Pit Table 48x48x22																			
SIZE A	DWG. NO. NPLL-ASM-48x48x22	REV A																	
SCALE: 1:16		WEIGHT:	SHEET 1 OF 1																
FINISH TBD		DO NOT SCALE DRAWING																	