

Optional Glass Wind Screen

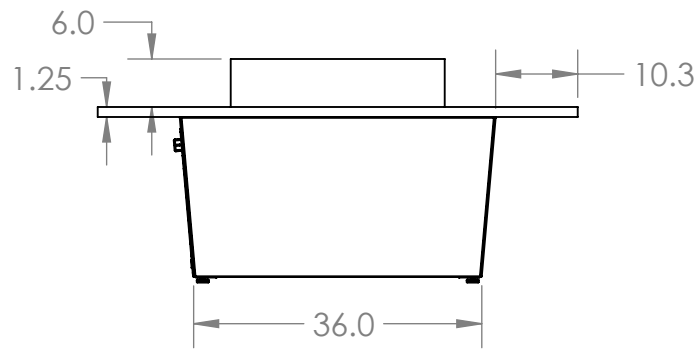
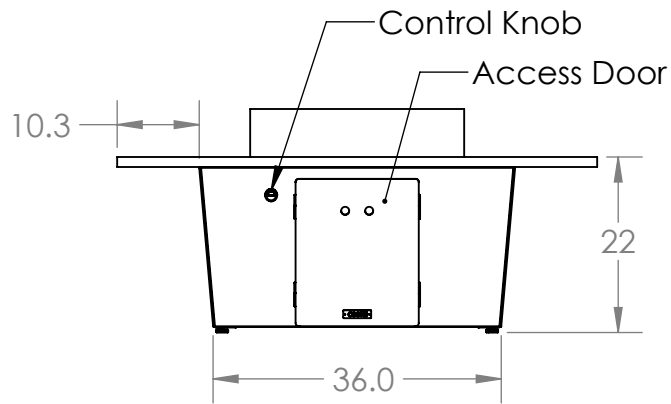
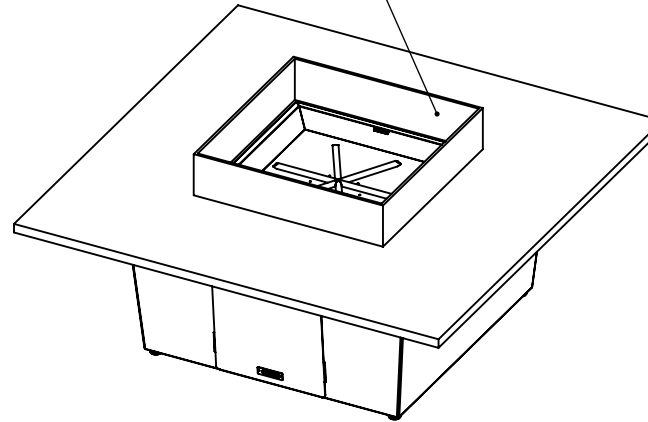

The Newport fire pit table is perfect for casual dining at 22 inches high, great for restaurants and social settings plus it can hide a standard propane tank in the base.

- Top Material
Granite Tier 1,2,3, Stainless steel or Custom selection
- Base Options
Copper plating with option of forced patina
Brushed or polished 304 stainless steel
Powder coating in several standard colors or custom colors are available
- Fire pit media
Broken Glass, Lava rock
Custom options include Ceramic stones, logs, etc.
- Fuel 100,000 BTU
Propane or Natural gas
- Optional forced air heat requires a 120 v 15 amp switched power
- Optional electronic Ignition requires 120v switched power
- Optional LED Lighting requires 120v switched power or Battery pack

UNLESS OTHERWISE SPECIFIED:

DIMENSIONS ARE IN INCHES
TOLERANCES:
FRACTIONAL $\pm 1/32$
ANGULAR: MACH $\pm .5^\circ$ BEND $\pm 1^\circ$
TWO PLACE DECIMAL $\pm .05$
THREE PLACE DECIMAL $\pm .010$

INTERPRET GEOMETRIC TOLERANCING PER: ANSI

MATERIAL
304SS/Stone

FINISH
TBD

DO NOT SCALE DRAWING

PROPRIETARY AND CONFIDENTIAL

THE INFORMATION CONTAINED IN THIS DRAWING IS THE SOLE PROPERTY OF DCI LLC. ANY REPRODUCTION IN PART OR AS A WHOLE WITHOUT THE WRITTEN PERMISSION OF DCI LLC IS PROHIBITED.

COMMENTS:

COOKE

CONTEMPORARY FURNITURE

info@cookefurniture.com 888-303-2453

TITLE:

Newport Fire Pit Table
60x60x22

SIZE	DWG. NO.	REV
A	NPLL-ASM-60x60x22	A
SCALE: 1:24	WEIGHT:	SHEET 1 OF 1